



Fusion° Apollo™ MS-API2000 Monoblock Amplifier Installation Instructions

Important Safety Information

WARNING

See the *Important Safety and Product Information* guide in the product box for product warnings and other important information.

This device must be installed according to these instructions.

Disconnect the vessel's power supply before beginning to install this device.

CAUTION

Continuous exposure to sound pressure levels over 100 dBA may cause permanent hearing loss. The volume is typically too loud if you cannot hear people speaking around you. Limit the amount of time you listen at high volume. If you experience ringing in your ears or muffled speech, stop listening and have your hearing checked.

To avoid possible personal injury, always wear safety goggles, ear protection, and a dust mask when drilling, cutting, or sanding.

NOTICE

YOU MUST NOT USE THIS AMPLIFIER WITH ANY THIRD-PARTY MARINE AUDIO SYSTEMS. This amplifier is compatible only with Fusion DSP-enabled marine audio equipment and may cause damage to third-party speakers due to the amplifier power output.

When drilling or cutting, always check what is on the opposite side of the surface to avoid damaging the vessel.

It is strongly recommended that you have your audio system installed by a professional installer to ensure optimum performance.

You must read all installation instructions before beginning the installation. If you experience difficulty during the installation, go to support.garmin.com for product support.

After installing an audio system, you should run the connected speakers and subwoofers at low to medium volumes for the first few hours of use. This helps to improve the overall sound by gradually loosening up the moving components of new speakers and subwoofers, such as the cone, spider, and surround. See the installation instructions provided with your speakers, because there may be more details about the recommended time for each model.

NOTE: After installing the amplifier, you must set up your connected stereo using the Fusion-Link™ app to select and activate the correct DSP profile.



Tools Needed

- Drill and 3 mm ($\frac{1}{8}$ in.) drill bit (or a drill bit appropriate for your provided mounting hardware and mounting-surface material).
- Screwdrivers:
 - 5 mm ($\frac{7}{32}$ in.) flat (slotted)
 - 4 mm ($\frac{5}{32}$ in.) flat (slotted)
 - #2 Phillips
 - #0 Phillips
- Wire cutter
- Wire stripper
- Wires and cables:
 - 4 AWG (21 through 25 mm²) marine-grade, fully-tinned copper wire for power and ground
NOTE: You may need larger-diameter (smaller gauge number) wire for longer runs to account for voltage drop ([Connecting to Power, page 8](#))
 - 12 AWG (3 through 4 mm²) marine-grade, fully-tinned copper wire for speakers
You can purchase this wire from your Fusion or Garmin® dealer.
 - 010-12898-00: 7.62 m (25 ft.)
 - 010-12898-10: 15.24 m (50 ft.)**NOTE:** You may need larger-diameter (smaller gauge number) wire for longer runs of speaker wire.
 - 20 AWG (0.5 through 0.75 mm²) marine-grade, fully-tinned copper wire for the remote-on signal
 - 1-channel RCA cable ([Signal and Speaker Connection Considerations, page 9](#))
You can purchase a suitable length of RCA cable at garmin.com/apollo_amplifier_accessories or from your Fusion or Garmin dealer.
- Cable ties (optional)

Mounting Considerations

⚠ CAUTION

In high ambient temperatures and after extended use, the device enclosure may reach temperatures deemed dangerous to touch. To avoid possible personal injury, the device must be installed in a location where it will not be touched during operation.

NOTICE

This device should be mounted in a well-ventilated location that is not exposed to extreme temperatures or conditions. The temperature range for this device is listed in the product specifications. Extended exposure to temperatures exceeding the specified temperature range, in storage or operating conditions, may cause device failure. Extreme-temperature-induced damage and related consequences are not covered by the warranty.

If you are mounting the device on fiberglass, when drilling the pilot holes, use a countersink bit to drill a clearance counterbore through only the top gel-coat layer. This will help to avoid cracking in the gel-coat layer when the screws are tightened.

This device is designed for installation only in a dry location. Installing this device in a location where it may come in contact with more than occasional dripping water or become submerged may result in damage. Water damage is not covered by the warranty.

You can mount this device using one of two methods:

- You can use the included bracket and pan head screws to mount the device (*Installing the Mounting Bracket, page 4*).
 - Mounting the device using the bracket allows you to quickly attach and detach the device from the mounting surface.
 - Mounting the device using the bracket requires clear space above the mounting location to allow for connecting the device to the bracket and installing the locking wedge.
- You can use the included flat-head, countersunk screws to mount the device directly to the mounting surface (*Mounting the Device Directly to the Surface, page 7*).
 - Mounting the device directly to the surface does not allow you to quickly detach the device.
 - Mounting the device directly to the surface does not require as much clear space above the mounting location, so it may be a more suitable choice for installing in a smaller space.

When selecting a mounting location, observe these considerations:

- You must mount the device in a location that does not interfere with the fuel tank or electrical wiring.
- You must mount the device in a location where it is not exposed to water.
- You must mount the device in a location where it is not exposed to fuel or fuel vapor.
- You must mount the device in a location with adequate ventilation where it is not exposed to extreme temperatures.
- If you mount device in an enclosed space, you should install a cooling fan with appropriate ducts to aid in airflow.
- You should mount the device so that the cables can be connected easily.
- To avoid interference with a magnetic compass, you should mount the device the specified distance away from a compass. This distance is listed in the specifications section.
- You must not mount the device in close proximity to other navigation-critical equipment, antennas, or radio-communication equipment on the vessel.

Installing the Mounting Bracket

NOTICE

Pan-head screws are included, but they may not be suitable for the mounting surface. If you provide different mounting hardware, you must not use fasteners with a countersunk head. Hardware with a countersunk head will damage the mounting bracket.

Before you install the mounting bracket, you must select a mounting location and determine what screws and other mounting hardware are needed for the surface.

Mounting the device using the mounting bracket allows you to quickly attach and remove the device as needed.

- 1 Use the included template to verify that the mounting location has sufficient clearance to install the device.

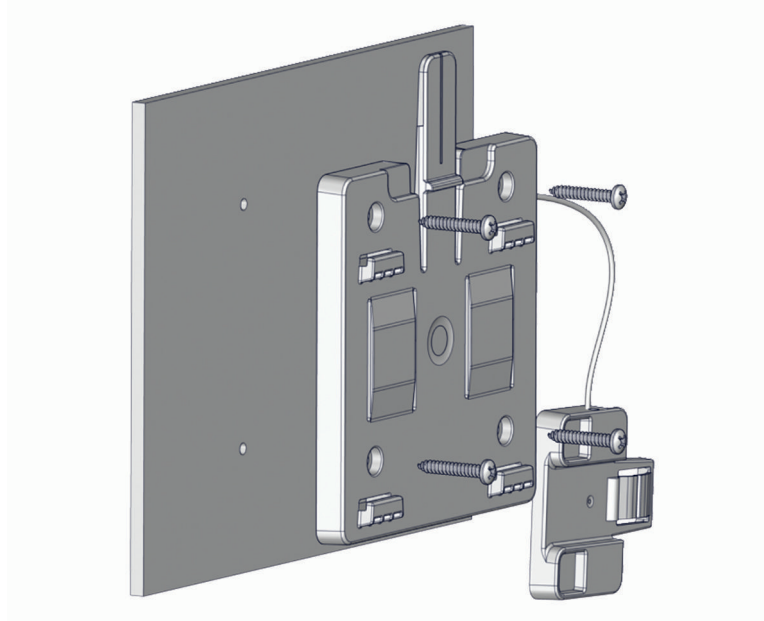

NOTE: You must install the bracket with the release tab pointing up to properly secure the amplifier in the bracket.

- 2 Using a 3 mm ($1/8$ in.) bit or a bit appropriate for your provided hardware and mounting-surface material, drill the pilot holes marked on the template.

NOTICE

If you are mounting the device on fiberglass, when drilling the pilot holes, use a countersink bit to drill a clearance counterbore through only the top gel-coat layer. This will help to avoid cracking in the gel-coat layer when the screws are tightened.

- 3 Using the included pan-head screws or other pan-head mounting hardware, secure the bracket to the mounting surface.

NOTICE

You must use pan-head screws, because countersunk screws will damage the bracket.

Connecting the Device to the Mounting Bracket

You must secure the mounting bracket to the surface before you can connect the device.

- 1 Hold the device over and slightly above the mounting bracket.

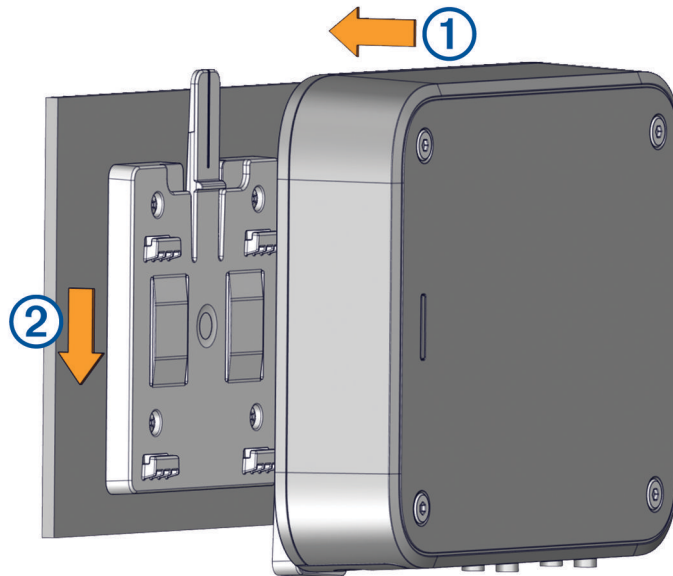

- 2 Place the device onto the bracket ① and pull down ② until the tab audibly clicks.
- 3 Insert the wedge over the tab on the top of the mounting bracket and push down to lock the device in the bracket.

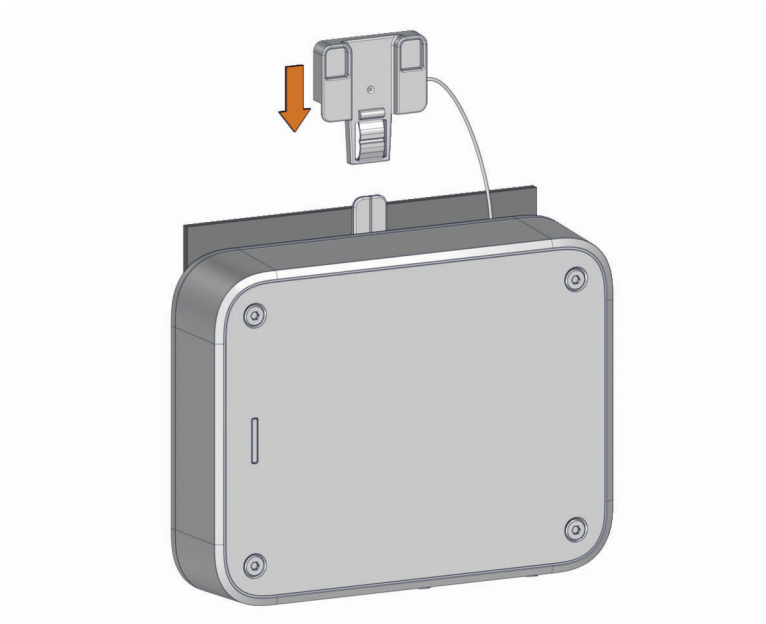

- 4 Install the included screw covers in the four holes on the top of the amplifier (optional).

Removing the Device from the Mounting Bracket

- 1 Lift up to remove the wedge, which unlocks the tab on the mounting bracket.

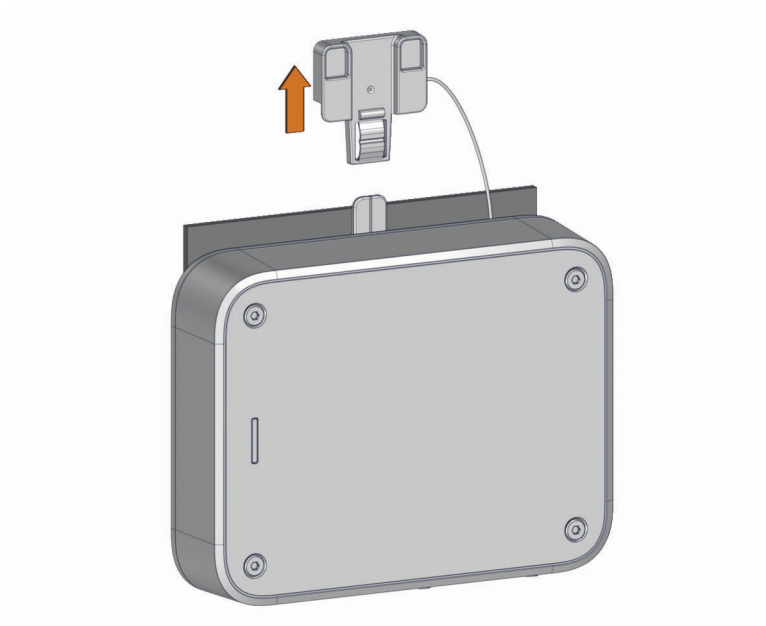

- 2 Press the tab ① on the mounting bracket, and lift up ② on the amplifier to disconnect it from the mount ③.

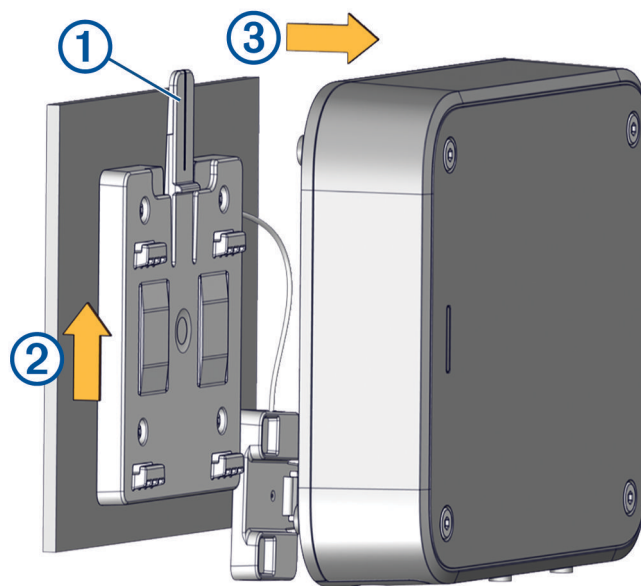

Mounting the Device Directly to the Surface

If you are installing the device in a location with limited space, or you do not want to use the bracket, you can mount the device directly to the surface.

NOTE: Countersunk screws are provided to mount the device directly to the surface. If you choose to use your own hardware to mount the device directly to the surface, countersunk heads are recommended.

- 1 Using the provided template, mark the pilot hole locations for the four mounting holes on the device, observing these considerations:
 - Because you are not using the bracket, you do not need to observe the upper clearance line on the template.
 - You must observe the lower clearance line on the template so that you have the space needed to make the cable connections.
- 2 Using a 3 mm ($1/8$ in.) bit or a bit appropriate for your provided hardware and mounting-surface material, drill the pilot holes.

NOTICE

If you are mounting the device on fiberglass, when drilling the pilot holes, use a countersink bit to drill a clearance counterbore through only the top gel-coat layer. This will help to avoid cracking in the gel-coat layer when the screws are tightened.

- 3 Using the provided countersunk screws, secure the device to the mounting surface.
- 4 Install the included screw covers in the four holes on the top of the amplifier (optional).

Connection Considerations

NOTICE

You should turn off the audio system before making any connections to the amplifier. Failure to turn off the audio system may result in damage to the audio system.

All terminals and connections must be protected from contact with the vessel chassis and with each other. Improper terminal or wire contact may result in damage to the audio system.

NOTE: You must connect the amplifier to the AMPLIFIER ON wire from the stereo for the amplifier to turn on and off with the stereo.

Port Identification

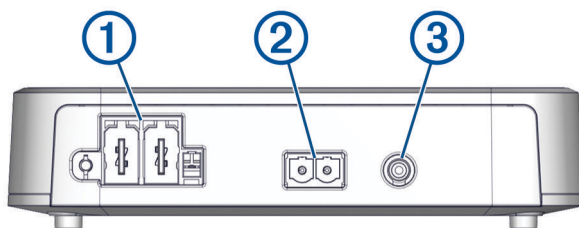

- ① Power block port ([Connecting to Power](#), page 8)
- ② Subwoofer speaker block port ([Signal and Speaker Connection Considerations](#), page 9)
- ③ RCA input port

Connecting to Power

⚠ CAUTION

The wiring (not included) from the power source to the amplifier must run through an inline fuse or circuit breaker (not included) as close to the power source as possible. You must connect the positive wire to the fuse or circuit breaker. Connecting the amplifier to power without an inline fuse or circuit breaker may result in a fire if there is a short in the cable.

If the amplifier is powered by a battery, use a breaker or fuse rated to protect a cable of the gauge used to connect the amplifier to the battery. See the American Boat & Yacht Council (ABYC) standards for the required fuse or breaker rating.

If the amplifier is powered by a source other than a battery, use a breaker or fuse rated no higher than the max current of the power source.

You should use 4 AWG (21 through 25 mm²) marine-grade, fully-tinned copper wire (not included) to connect the amplifier to power and ground for most installations. For long power-cable runs, you should consider using larger-diameter (smaller gauge number) wire to minimize power loss.

You must connect the REM terminal on the amplifier block to either the AMPLIFIER ON wire from the connected stereo or to a constant 12 Vdc power source using a switch.

NOTICE

Connecting to the AMPLIFIER ON wire is recommended to avoid damaging your speakers when the stereo turns on or off.

- 1 Route 4 AWG (21 through 25 mm²) marine-grade, fully-tinned copper ground wire (not included) to the amplifier and to a ground location on the boat.
- 2 Using a 5 mm (⁷/₃₂ in.) flat (slotted) screwdriver, connect the ground wire to the GND terminal on the power connection block.

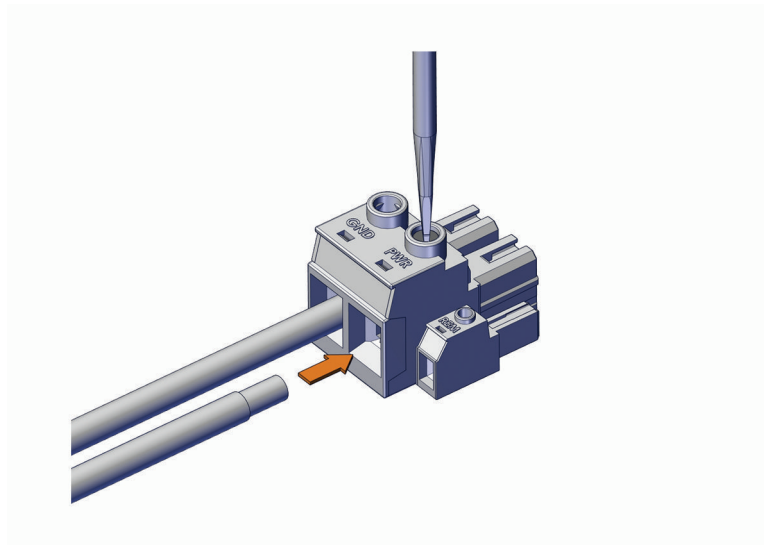

- 3 Connect the other end of the ground wire to the ground location.
- 4 Route 4 AWG (21 through 25 mm²) marine-grade, fully-tinned copper power wire (not included) to the amplifier and to the power source, and select an option:
 - Install a properly rated in-line fuse on the power wire as close to the power source as possible.
 - Identify or install a circuit breaker, as close to the power source as possible, for use with the amplifier power wire.

⚠ CAUTION

Connecting the amplifier to power without the proper inline fuse or circuit breaker as described above and in the specifications section may result in a fire if there is a short in the cable.

- 5 Using a 5 mm ($\frac{7}{32}$ in.) flat (slotted) screwdriver, connect the power (+) wire to the PWR terminal on the power connection block.
- 6 Route a 20 AWG (0.5 through 0.75 mm²) marine-grade, fully-tinned copper remote-on wire (not included) from the amplifier to the AMPLIFIER ON wire on the stereo.
NOTE: The amplifier and the stereo must connect to a common ground location for the AMPLIFIER ON signal to function properly.
- 7 Using a 4 mm ($\frac{5}{32}$ in.) flat (slotted) screwdriver, connect the remote-on wire to the REM terminal on the power connection block.

NOTICE

You should wait to connect the power terminal block to the amplifier. Make all of the other connections to the stereo and speakers before completing the connection to power ([Completing the Connections, page 11](#)).

Signal and Speaker Connection Considerations

When connecting your stereo and subwoofer to the amplifier, observe the following considerations:

- A subwoofer connects to the amplifier using a terminal block ([Connecting a Subwoofer to the Amplifier, page 10](#)).
- The amplifier supports a nominal 4 Ohm speaker load impedance, and a 2 Ohm minimum speaker load impedance.
- When connecting a subwoofer, you should use 12 AWG (3 through 4 mm²) marine-grade, fully-tinned copper wire.
- You must connect a 1-channel RCA cable from the subwoofer line out port on the stereo to the single-RCA input port on the amplifier.

Connecting a Subwoofer to the Amplifier

- 1 Route 12 AWG (3 through 4 mm²) marine-grade, fully-tinned copper wire to the subwoofer and the amplifier.
NOTE: You should label both ends of the speaker wire so you can easily identify which wires route to which speakers.
- 2 Connect the speaker wire to the subwoofer, observing polarity.
NOTE: Incorrectly connecting the speaker wire by crossing the polarity may result in poor sound quality.
- 3 Using a 4 mm (⁵/₃₂ in.) flat (slotted) screwdriver, connect the speaker wires to the speaker terminal block.
NOTE: The speaker terminal block is not labeled. Refer to the label on the amplifier port when determining polarity.

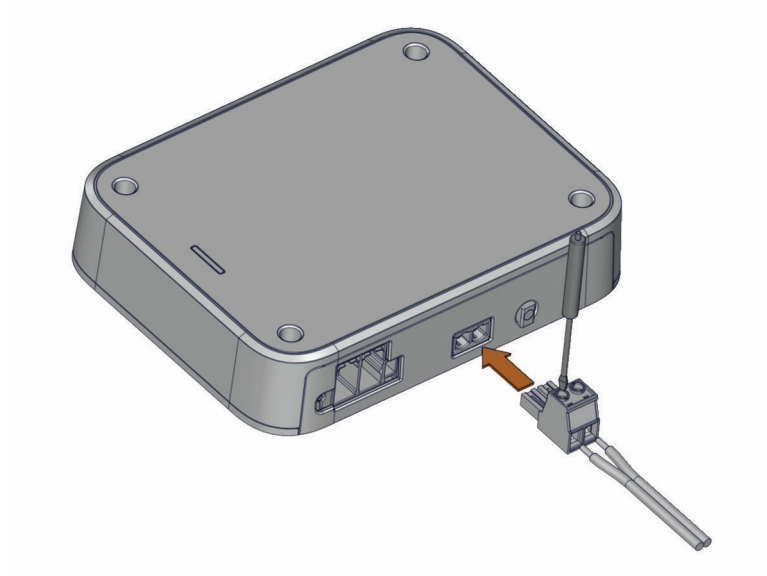

- 4 When both speaker wires are connected to the terminal block, press the assembled terminal block into the port on the amplifier to complete the subwoofer connection.
- 5 Connect a 1-channel RCA cable to the RCA subwoofer line-out connector from the stereo for a zone you want to use with the subwoofer.
- 6 Connect the other end of the 1-channel RCA cable to the single RCA input port on the amplifier.

Completing the Connections

Before you connect the amplifier to the power source, you should complete all other connections to the amplifier .

- 1 Make sure the speaker wire is connected between the subwoofer and the amplifier, using a speaker terminal block.
- 2 Make sure the RCA cable is connected between the stereo and the amplifier.
- 3 Make sure the power and ground cables are connected to power terminal block and the power source (*Connecting to Power*, page 8).
- 4 Make sure the amplifier remote-on wire is connected to the power terminal block and to the amplifier turn-on wire from the stereo (*Connecting to Power*, page 8).
- 5 Insert the assembled power terminal block into the power port on the left side of the amplifier.

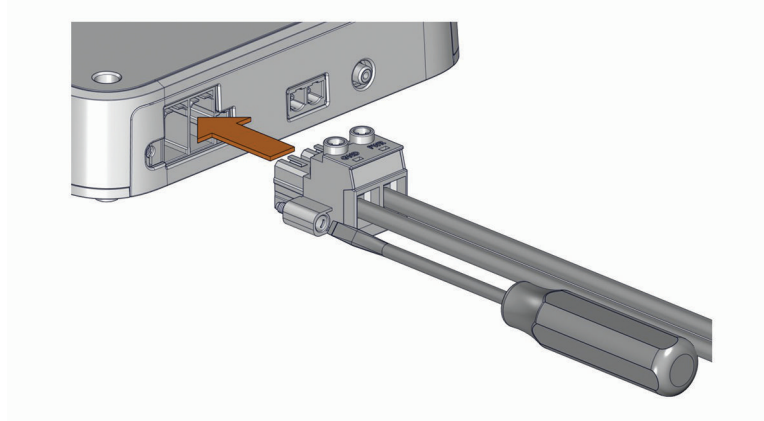

- 6 Using a 5 mm ($7/32$ in.) flat (slotted) screwdriver, secure the power terminal block to the amplifier.

NOTICE

After you have completed all connections, you must configure the DSP profile for the amplifier before playing music. If the DSP profile is not set up, you may damage the connected speakers (*Configuring the Amplifier*, page 11).

Configuring the Amplifier

To configure the amplifier for use with your stereo and speakers, you must use the Fusion-Link app to set up the DSP profile after you have completed the connections.

TIP: You can view a video tutorial to help setup a DSP profile for your system at garmin.com/videos/fusion_link_app.

- 1 Follow the instructions in your stereo owner's manual to download the Fusion-Link app and connect it to the stereo.
- 2 Select the appropriate amplifier, speakers, and/or subwoofer(s) for each zone in the Fusion-Link app.
- 3 Follow the instructions in the Fusion-Link app to select a configured profile for the connected amplifier, speakers, and/or subwoofer(s).
- 4 Send the DSP profile to the connected stereo and test the sound.
- 5 Repeat steps 3 and 4 until the audio system sounds satisfactory.

Specifications

Compass-safe distance	75 cm (30 in.)
Operating temperature range	From -0 to 50°C (from 32 to 122°F)
Storage temperature range	From -20 to 70°C (from -4 to 158°F)
Water rating	IEC 60529 IPX2 ¹
Maximum wire gauge	Power: 2 AWG (33.63 mm ²) Speakers: 10 AWG (5.26 mm ²)
Weight	2.2 kg (4 lbs 13.6 oz)
Amplifier class	Class D
Frequency response	20 Hz to 3.5 kHz (4 Ohm)
CEA-2006 power rating @ 14.4 Vdc, 4 Ohm, ≤ 1% THD+N, 50 Hz, AES17-20 kHz BW	650 W RMS
CEA-2006 power rating @ 14.4 Vdc, 2 Ohm, ≤ 1% THD+N, 50 Hz, AES17-20 kHz BW	1100 W RMS
Peak power output	2000 W
Input impedance	22 kOhm
Input sensitivity @ rated power output, 4 Ohm	2.15 Vrms
Signal to noise ratio @ rated power output, 4 Ohm	101 dBA
Signal to noise ratio @ 1 W, 4 Ohm	75 dBA
Operating voltage	10.8 to 16 Vdc
Current draw, standby (@14.4 Vdc input)	less than 5 mA
Current draw, on, no audio (@14.4 Vdc input)	1.15 A
Breaker or cable-fuse rating	If the amplifier is powered by a battery, use a breaker or fuse rated to protect a cable of the gauge used to connect the amplifier to the battery. See the ABYC standards for the required fuse or breaker rating. If the amplifier is powered by a source other than a battery, use a breaker or fuse rated no higher than the max current of the power source.
Internal fuse rating	Internal electronic fuse. No replacement necessary. 125 A
Remote turn-on	Greater than 4 Vdc
Protection circuits	Reverse voltage Input under/over voltage Over temperature Output short circuit

¹ Protection against vertically-dripping water when installed properly with the connectors pointing downward.

Dimensions

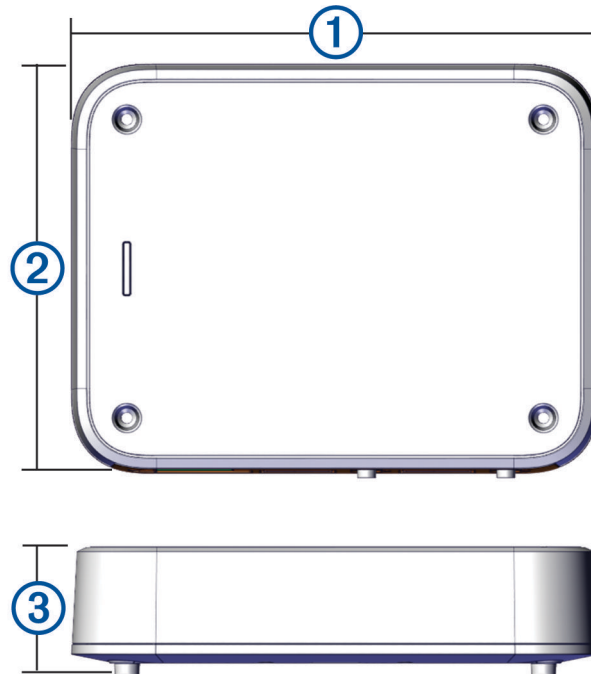

①	235 mm (9 1/4 in.)
②	180 mm (7 1/16 in.)
③	45 mm (1 3/4 in.)

More Information

Troubleshooting

Before you contact your Fusion dealer or service center, you should perform a few simple troubleshooting steps to help diagnose the problem.

If the Fusion amplifier has been installed by a professional installation company, you should contact the company so a technician can assess the problem and advise you about possible solutions.

LED Power Indicator Bar Colors

The single LED power indicator bar on the front of the amplifier changes colors to indicate status and potential faults. You can use these tables to reference the LED colors when troubleshooting the amplifier.

LED Color	Status
Off	Power off
Green	Operational
Orange	Recoverable fault
Red	Critical fault

LED is Off

Potential Cause	Potential Resolution
Power connection issue (Connecting to Power, page 8)	<ul style="list-style-type: none">• Check the power wiring connections to the power terminal block and make sure they are securely connected using the terminal screws.• Check the connection between the power terminal block and the amplifier, and make sure it is seated securely in the port.• Check the power-wiring connections to the fuse or circuit breaker and to the battery and repair or tighten any disconnected or loose wires.• Check the circuit breaker and reset it if necessary.• Make sure the supply voltage is within the specified operational range for the amplifier.• Make sure you are using the appropriate gauge for the length of the power cable run, and replace the cable with a thicker gauge, if needed.
Remote turn-on wire connection issue	<ul style="list-style-type: none">• Check the remote turn-on wire connection to the power terminal block and make sure it is securely connected using the terminal screws.• Check the remote turn-on wire connection to the stereo and repair or tighten a disconnected or loose wire.• Make sure that the stereo and the amplifier are connected to a common power ground.• If you connected the remote turn-on wire to a switch instead of the stereo, make sure the switch is installed correctly.

LED is Green and There is No Sound

Potential Cause	Potential Resolution
Power or volume issue	<ul style="list-style-type: none">• Make sure the stereo is powered on.• Make sure the volume is not set too low or muted.
DSP settings issue	<p>Check the DSP settings in the Fusion-Link app and make sure the correct speakers, stereo, and amplifier are selected.</p> <p>NOTE: You must select the option in the app to send the DSP settings to the devices after you configure the settings.</p>
Signal or speaker connection issue	<ul style="list-style-type: none">• Check the RCA cable connections to the stereo and the amplifier, and re-connect all disconnected cables, if needed.• Check the speaker wiring connections to the speaker terminal blocks and make sure they are securely connected using the terminal screws. Reconnect or tighten the wires, if needed.• Check the connection between the speaker terminal blocks and the amplifier, and make sure they are seated securely in the ports

Potential Cause	Potential Resolution
	<ul style="list-style-type: none"> Check the wire gauge used to connect the speakers to the amplifier, and make sure it is appropriate for the length of the wire run (<i>Signal and Speaker Connection Considerations, page 9</i>).
Power issue	Check the power cables to make sure they are the appropriate gauge, are fused, and are connected properly (<i>Connecting to Power, page 8</i>).

LED is Green the Sound is not Optimal

Issue	Potential Resolution
There is a hum or other unexpected noise from a speaker	Install ground-loop isolators inline with the RCA cables from the stereo. NOTE: You should install ground-loop isolators on the RCA cables where they connect to the stereo, not where they connect to the amplifier.
The sound is distorted or clipping	Check the DSP settings in the Fusion-Link app and make sure the correct speakers, stereo, and amplifier are selected. NOTE: You must select the option in the app to send the DSP settings to the devices after you configure the settings.
Bass response is reduced or uneven	Check the DSP settings in the Fusion-Link app and make sure the correct speakers, stereo, and amplifier are selected. NOTE: You must select the option in the app to send the DSP settings to the devices after you configure the settings.

LED is Orange

Potential Cause	Potential Resolution
Power supply under- or over-voltage issue	Check the input power to make sure it is within the 10.8 to 16 Vdc operational range for the amplifier.
Power wire gauge issue	Check the wire gauge used to connect the amplifier to power, and make sure it is appropriate for the length of the wire run.
Over-temperature issue	Check the temperature of the amplifier and make sure it is under 50°C (122°F). If the amplifier is hotter than the operational temperature rating, add ventilation to the installation location or mount the amplifier in a different location.

NOTE: The amplifier will automatically attempt to recover from a recoverable fault (orange LED). If multiple attempts of recovery are not successful, then the amplifier will transition to a critical fault status (red LED). You can power cycle the amplifier or toggle the AMPLIFIER ON signal to reset the critical fault.

LED is Red

Potential Cause	Potential Resolution
Power supply under- or over-voltage issue	Check the input power to make sure it is within the specified voltage operating range for the amplifier. If the amplifier experiences a number of under-voltage faults (orange LED) in a short period of time, it will consider the issue a critical fault and change the LED color to red. Therefore, a series of orange indicators followed by a red indicator may be due to an under-voltage issue.
Prolonged over-temperature issue	Check the temperature of the amplifier and make sure it is under 50°C (122°F). If the amplifier is hotter than the operational temperature rating, add ventilation to the installation location or mount the amplifier in a different location.

Potential Cause	Potential Resolution
DSP setting or volume issue	Check the DSP settings in the Fusion-Link app and make sure the correct amplifier, speakers, and/or subwoofer(s) are selected. NOTE: You must select the option in the app to send the DSP settings to the stereo after you configure the settings.
Speaker fault	Check all connected speaker wires. <ul style="list-style-type: none"> Make sure the speaker wires are connected to the speaker terminal blocks and to the speakers properly. Make sure there are no shorts in the speaker wires, and that there are no cuts in the speaker-wire jackets that may result in a short.
Internal amplifier or power supply fault	Disconnect the amplifier from the power source for one minute, then reconnect it and test for proper operation. If the LED continues to show a red fault, contact support.

物質宣言

部件名称	有毒有害物质或元素					
	铅	汞	镉	六价铬	多溴联苯	多溴二苯醚
电路版	○	○	○	○	○	○
箱体	○	○	○	○	○	○
附件	○	○	○	○	○	○

本表格依据 SJ/T11364 的规定编制。

○: 代表此种部件的所有均质材料中所含的该种有害物质均低于 (GB/T26572) 规定的限量

✗: 代表此种部件所用的均质材料中, 至少有一类材料其所含的有害物质高于 (GB/T26572) 规定的限量

* 该产品说明书应提供在环保使用期限和特殊标记的部分详细讲解产品的担保使用条件。



产品